



# NEW HOLLAND

L315 L318 L320 L323 L325 L330  
**SKID STEER LOADERS SERIES 300**



**300**  
**SERIES**

A Brand of CNH Industrial



**NEW HOLLAND**  
CONSTRUCTION

# Always with you

No matter what your industry, construction, farming or agriculture –, you will do your work more efficiently with the New Holland 300 Series Skid Steer Loader.

The new range of New Holland 300 Series Skid Steer Loaders and Compact Track Loaders delivers on its promise.

These 60 to 90 HP gross horsepower Skid Steer Loader offer unmatched performance and versatility.

Whether you're a farmer, contractor or landscaper, the new 300 Series Skid Steer Loaders and Compact Track Loaders are designed to support you and your operation.

## Increased stability

The New Holland skid steer loader, which already had a longer wheelbase, combined with a low gravity center and correct weight distribution, that distance left the ride more stable. All of this is to make your work more productive and safe.



## Unmatched dump height and reach

The New Holland patent Super Boom® arm provides more height and unloading reach, allowing the operator to better distribute the load in high-rise trucks or silos.

## More comfort for the operator

New Holland knows that comfort is not simply a luxury item, it is essential to your business. An operator, feeling comfortable, works longer hours, with less fatigue. Therefore, we make sure to build additional comfort when designing the 300 Series.

- Optional seat, covered with fabric, air suspension and heating, offer maximum comfort, reducing fatigue.
- Our joysticks are ergonomically designed to place all the commands at the tip of your fingers. In addition, it is possible to switch the operation mode between the ISO H.
- The air vents are strategically located, for better thermal distribution inside the cab and quick demisting of the glazed area, when necessary.



## Easy maintenance

With regard to maintenance, New Holland understands that the machine downtime is a loss of income and that daily maintenance will be well performed if control points are easily accessible.

- Simply open the rear door of the engine compartment to easily identify maintenance points such as filler neck and engine dipstick; air filter; hydraulic and engine oil radiator; coolant expansion tank and fuel and oil filters. Battery maintenance is easy too.
- If you need more access for maintenance, the folding cab allows full access to the interior of the machine.



\*ISO 5006: The 3006 specifies a static test method to determine and evaluate operator visibility, within a closed limit of 1m around the machine, and a 12m visibility test circle.



## **A legacy of height, dump reach, productivity and stability**

Although the 300 Series Skid Steer Loaders have been completely redesigned, they honor New Holland's long history in the skid steer loader market, while still maintaining the essential *design* features that made them so productive.

### **The New Holland heritage: to handle larger loads and move them faster.**

The 300 Series Skid Steer Loaders provide the best stability and visibility allowing operators to move larger loads and work at a new level of confidence.

# Super Boom®: the best height and reach of discharge and stability; yesterday, today and tomorrow

## The New Holland L35 was the first vertical motion skid steer loader

Launched in 1972, the New Holland L35 was the first vertically moving skid steer loader equipped with the Super Boom® arm. Since then, more than 250,000 New Holland skid steer loaders have been sold with the Super Boom®. Today, New Holland skid steer loaders are manufactured in Wichita, Kansas, and distributed to more than 100 countries. New Holland is proud to carry on the tradition of the Super Boom® on the 300 Series skid steer loaders.

As the boom rises, the load is shifted forward, not back, toward the operator. Outcome: greater reach and height allowing the material unloading in places where the others do not reach (in the middle of the high body of a truck, for example). The operator's seat on New Holland skid steer loader is lower, keeping the operator totally safe. When you consider that New Holland has the longest wheelbase in the industry and the lowest center of gravity, it means that New Holland skid steer loader are known for their excellent stability.



# See how a skid steer loader can be so much better

Visibility is very important to operators. And New Holland understands that. Full visibility is obtained on the 300 Series - from the cutting edge, from the bucket at maximum height and the entire side and rear operating area. Your job will be done faster and more efficiently with this skid steer loader.

## Full visibility

- The front door sill on the 300 Series was lowered, allowing even better visibility to the bucket and digging area.
- The transparent area on the cab roof offers a clear view of the bucket at full height.
- The 300 Series side grilles are thinner, have wide visibility in critical areas (as defined by ISO 5006).



## The 300 Series Cab

- Rear visibility is the best in the industry, offering a wide window, lower engine hood, and no rear structural towers.



## Comfortable, clean and quiet environment

- A huge glass door opens to make it easier for the operator to enter and exit. When closed, it provides full visibility in all directions creating a pleasant feeling of open space.
- HVAC (hot/cold) type air conditioning provides the ideal temperature in any weather condition.
- The headliner provides a low noise level inside the closed cab, due to its insulating power.
- The cab sealing reduces dust infiltration.
- The headlights are mounted on the upper extremities of the cab, offering a wide illuminated area and also aiding in the positioning of high loads, besides facilitating visibility for maneuvers in dimly lit areas. The ample space for legs and feet increases operator comfort.
- A cab equipped with a demolition door is available optionally, which, in turn, is ROPS (Roll Over Protection System) certified, in accordance with ISO 3471 requirements.

## Other features that are *default* and related to visibility:

- Roof light.
- Top window.
- Reverse alarm and horn.
- Halogen work lights – two front and two rear – for longer working life and excellent visibility of the work area.
- Prepared for flashlight.
- Taillights for drive, brake and position.
- Warning lights with alarm (engine coolant temperature, engine oil pressure, air filter restriction, hydraulic filter restriction, hydraulic oil temperature).
- Indicator lights (engine preheating, parking brake, seat belt not on).



The panoramic front windshield offers excellent vision, while the spacious cab provides a comfortable environment for the operator.

## Inner comfort

An operator, feeling comfortable, works longer hours, with less fatigue. The Skid Steer Loaders

The New Holland 300 Series ones are at the forefront and lead the industry in dimensions, options and easy operation.

- Lower hearth.
- Leveled floor.
- Widest cab in the industry.

## Control lever options

New Holland Skid Steer Loaders are equipped with control levers or a electro-hydraulic command *joystick*, where the ISO or H operating mode can be selected on the front panel, available on models L318 to L330.

The skid steer loaders offer a choice of 2 speed modes on the L318 - L330 models and a quick change bucket option.



The switches are positioned on the control levers allowing for an easy operation of features such as horn, proportional flow, direction lights, two speeds, bucket jitter, multiple functional attachment controls and the LTS (Load Travel Stabilizer).





The step floor is leveled for easy entry/exit and there is more room for leg and foot.

### Cab comfort

With the lowest lot, leveled floor and the conveniently positioned control levers, access to the cab was even easier.

All of the New Holland 300 Series Skid Steer Loaders come equipped with ROPS/FOPS cab and retractable seat belt (3-point belt is default only for the enclosed cabs). All models offer cloth-lined air suspension seats – optional – for additional comfort.

All switches and measuring instruments are positioned well in front of the operator, providing easy access and reading for the operator.

More options for the operator compartment:

- Enclosed cab with heating and air conditioning.
- ROPS/FOPS certified cab
- Quick coupling, hydraulic.
- Block heater.
- Direction lights.
- *Self level.*
- LTS (Load Travel Stabilizer).
- High Flow Hydraulic System – High Performance.
- Radio with speakers.
- Side windows for easy removal and cleaning (no tools required).



## Hard work and harsh conditions?

The New Holland skid steer loaders are true workhorses, tackling any type of operation. The New Holland 300 Series Skid Steer Loaders have been developed with reliable high performance engines, low fuel consumption and easy maintenance, seeking to reduce operating costs.



### **New Holland/FPT Engines (L323, L325 and L330)**

#### **High performance, in any condition**

These engines are noted for their low cost operation, extremely easy maintenance and excellent performance in the most demanding applications.

- The engines are turbocharged and with the EGR (Exhaust Gas Recirculation) system are able to reduce the emission of pollutants without losing power.
- Fuel injection is direct and powered by a mechanically driven rotary pump that provides the proper amount of fuel.
- The engine design with a counterweighted crankshaft provides low noise and low vibration.
- Engine components, such as water pump and oil cooler, are incorporated into the structure thus preventing leaks.
- The precision in the engine manufacturing provides more precise clearances between the parts, mainly between the rings, increasing the engine oil change interval to 500 hours, reducing operation and maintenance costs.



Hydraulic system "High-Flow" is available optionally, for the L318, L320, L323, L325 and L330 models.



## ISM\* Engines (L315, L318, L320)

### Clean, compact, quiet and easy to maintain

- The injection system supplies the necessary amount of fuel for the combustion chamber to burn efficiently, producing more power and torque with the ideal amount of fuel.
- Engines with low emission of pollutants and energy consumption are less aggressive to the environment.
- Rigid block engine, with small diameter cylinders, reduces vibration and noise – from idle to maximum speed –, increasing the operator comfort.
- The well-balanced, compact motor is tough and durable. These engines design allows for the ability to interchange parts between the various models.
- All of the components that need daily maintenance are located only on one side of the engine, speeding maintenance.
- 500 hour maintenance intervals lower operating costs as well as time spent on maintenance.

\* IHI SHIBAURA MACHINERY CORPORATION

### Excellent performance in any weather condition

- Glow plugs – standard.
- Maintenance-free, easy-access standard battery produces up to 925 CCA for all models.
- Reliable starter engine for quick starts.
- Heavy-duty upper and lower radiator/oil cooler configuration for high cooling capacity in the most extreme conditions. Rigid assembly reduces vibration and tipping makes cleaning easy.

### Quick response hydraulics.

- Quick work cycles.
- In-line hydraulic pumps produce less noise and result in a smooth and quiet operation.
- Hydraulic system "High-Flow" (optional between the models L318 to L330) provides better performance in accessories that need high flow.
- The "High Performance" hydraulic system is available optionally for the L330.
- The SAHR (spring applied, hydraulically released) parking brake can be released or applied through a button. It is automatically activated when the machine is switched off.

### Extra performance

- Two-speed transmission, can reach up to 20 km/h, saving travel time within the workplace. Optional for models
- L318, L320, L323, L325 and L330.



The operator will be able to engage and disengage the arm lock from inside the cab for added safety when starting the machine with the arm raised.



For quicker and easier maintenance, the battery is located on the side of the machine along with the engine oil drain and filter.



## Easy access for maintenance

New Holland has realized: if access for maintenance is difficult, tasks will often fail to be performed.

To speed up service and make it more convenient, New Holland has grouped the daily maintenance items together. Now, the main components of the machine are easily accessed, all you have to do is tilt the cab forward.

### Facilitated maintenance

- Wide access for daily checks like engine oil level, fuel supply, hydraulic oil, coolant and the radiator needs no tools for access.
- The radiator can be cleaned on both sides.

### Maintenance intervals

- Every 500 hours, change the engine oil and filter.
- Every 500 hours, replace the primary fuel and hydraulic oil filters.
- Every 1,000 hours, drain and flush radiator. Spend more time producing and less on daily checks.

### Built to last

- New Holland combined elements of the previous skid steer loader Super Boom® arm design with proven technology from New Holland front loaders to develop a rugged and reliable design for the 300 Series.

### Operator resources

- Exclusive arm locking bracket that, when attached, keeps it in the raised position (vertical lift models).
- Without leaving the cab, operators are able to engage and disengage the boom safety lock (vertical lift models).

### Unmatched access

In case of need, the cab can be completely tilted forward, loosening just two screws, allowing ample access to the components. To tip the cab over, the boom must be fully raised.





**The New Holland equipment comes with a standard 1-year warranty, unlimited hours.**

The hinged rear door provides wide access to quickly check engine oil, hydraulic oil, coolant and fuel fill.



# Master in multitasking

The New Holland skid steer loaders do much more than just lift and carry. Check out the variety of accessories and see how the versatility of these machines can make you even more productive.

- 4x1 Bucket
- Tilting broom without collector
- Soil drill
- Hydraulic rake
- Backhoes
- Handler for forage rolls
- Claw for forage rolls
- Claw
- Shredder
- Cold milling machine
- Concrete bucket
- Concrete claw
- Shove
- Mixer
- Brooms
- Log claw
- Nails for manure
- Manure scraper
- Pallet forks
- Broom with collector
- Post installer
- Post extractor
- Side discharge bucket
- Soil preparer
- Rock bucket
- Root claw
- Circular saw
- Scrap claw
- Forage defragmenter
- Sediment scraper
- Bulldozer
- Steel tracks
- Log shredder
- Cultivator
- Tree bulldozer
- Tree transplanter
- Trencher
- Road roller

\* ACCESSORIES ARE NOT  
FACTORY PROVIDED,  
ONE MUST CONSULT  
DIRECTLY THE DEALERSHIP  
OR PARTS DEPARTMENT.



## Easy tool changes

No matter what you need to do – dig, lift, break rocks, ditch, flatten, sweep and drill – there is a New Holland tool that gets the job done

## Auxiliary pressure relief

A connecting under pressure hydraulic manifold (CUP) is standard equipment on all models and allows connection of all hydraulic accessories. By pushing the socket, the pressure is released for both the machine and accessory lines. You will never need a wrench set to open the pipe again.

- A. Drain for low and high flow auxiliary lines (oil return to reservoir)
- B. Quick coupling connector for low flow auxiliary line Ø5/8"
- C. Quick coupling connector for low flow auxiliary line Ø3/8"
- D. Quick coupling connector for high flow auxiliary line Ø5/8" coupling
- E. Quick coupling connector for high flow auxiliary line Ø3/8"



Optional high flow aids

## Quick hydraulic coupler option

Optional quick hydraulic coupler can increase work productivity allowing operators to change attachments quickly and safely.



# Skid Steer Loader Specifications

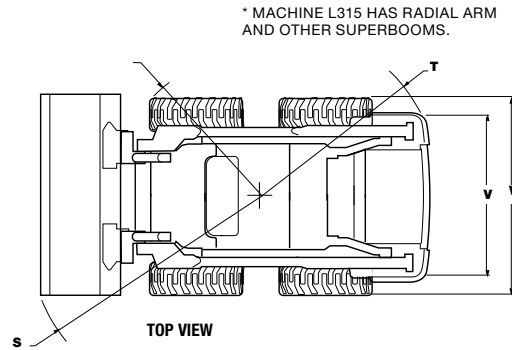
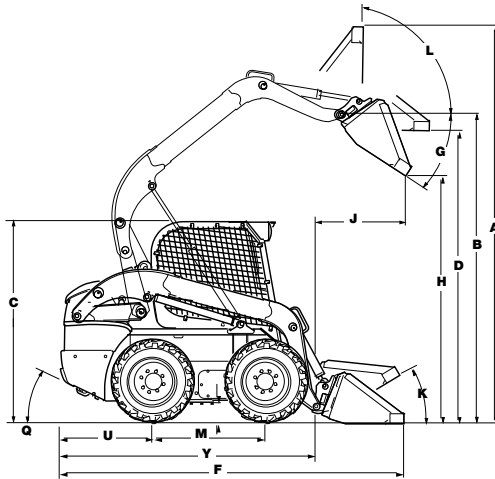

DIMENSIONS	L315 *	L318	L320	L323	L325	L330
<b>Total operating height</b>						
A. Low profile foundry/excavation, mm (in)	3591 (141.4)	3820 (150.4)	3845 (151.4)	4056 (159.7)	4056 (159.7)	4096 (161.3)
A. General purpose/light materials, mm (in)	3732 (146.9)	3927 (154.6)	3952 (155.6)	4159 (163.7)	4159 (163.7)	4204 (165.5)
A. General purpose/light materials - long profile, mm (in)	3859 (152)	4055 (159.6)	4080 (160.6)	4287 (168.8)	4287 (168.8)	4326 (170.3)
<b>Height up to</b>						
B. Bucket pin mm (in)	2845 (112)	3048 (120)	3073 (121)	3290 (129.5)	3290 (129.5)	3330 (131.1)
C. Cab top mm (in)	1919 (75.5)	1974 (77.7)	1998 (78.7)	2004 (78.9)	2004 (78.9)	2044 (80.5)
D. Maximum level bucket, mm (in)	2.682 (105.6)	2877 (113.3)	2902 (114.3)	3115 (122.6)	3115 (122.6)	3156 (124.2)
<b>Total Length</b>						
E. Without accessory, mm (in)	2435 (95.9)	2685 (105.7)	2685 (105.7)	2993 (117.8)	2987 (117.6)	2978 (117.3)
F. With casting bucket and ground excavation, mm (in)	3028 (119.2)	3352 (131.9)	3338 (131.4)	3633 (143.0)	3626 (142.8)	3617 (142.4)
F. General purpose bucket, mm (in)	3175 (125)	3546 (136.1)	3440 (135.4)	3736 (147.1)	3730 (146.8)	3725 (146.7)
F. With general purpose bucket and long profile, mm (in)	3297 (129.8)	3585 (141.1)	3569 (140.5)	3864 (152.1)	3858 (151.9)	3849 (151.5)
<b>Discharge</b>						
G. Dump angle, degrees	40.2	51.9	51.9	54.7	54.7	54.7
<b>H. Discharge height</b>						
Foundry/digging bucket, short edge, mm (in)	2246 (88.4) @ 40.2°	2380 (93.7) @ 45°	2405 (94.7) @ 45°	2618 (103.1) @ 45°	2618 (103.1) @ 45°	2658 (104.7) @ 45°
General purpose bucket and low profile, mm (in)	2154 (84.8) @ 40.2°	2305 (90.7) @ 45°	2330 (91.7) @ 45°	2544 (100.2) @ 45°	2544 (100.2) @ 45°	2580 (101.6) @ 45°
J. Dump reach (max. height), mm (in)	469 (18.5) @ 40.2°	783 (30.8) @ 45°	758 (29.8) @ 45°	810 (31.9) @ 45°	810 (31.9) @ 45°	765 (30.1) @ 45°
<b>Maximum bucket retraction</b>						
K. Bucket on the ground, degrees	26.1	35	34.4	33.6	33.6	33.1
L. Bucket at maximum height, degrees	95.2	87.6	87.6	84.8	84.8	84.8
<b>Wheelbase and ground clearance</b>						
M. Wheelbase, mm (in)	941 (37)	1128 (44.4)	1128 (44.4)	1322 (52)	1322 (52)	1322 (52)
P. Ground clearance, mm (in)	178 (7)	178 (7)	203 (8)	204 (8)	204 (8)	244 (9.6)
Q. Departure angle, degrees	22	23	25	23.5	23.5	26.5
<b>Turning radius</b>						
Without bucket, mm (in)	1240 (48.8)	1347 (53.0)	1340 (52.6)	1376 (54.2)	1376 (54.2)	1432 (56.4)
S. With 60" casting ladle in loading position, mm (in)	1862 (73.3)	2037 (80.2)	2062 (81.2)	2135 (84.0)	2135 (84.0)	2160 (85.0)
S. With 60" low profile bucket on ground, mm (in)	1994 (78.5)	2133 (84.0)	2156 (84.9)	2229 (87.7)	2229 (87.7)	2257 (88.8)
S. 60" long profile general purpose on ground, mm (in)	2112 (83.1)	2251 (88.6)	2273 (89.5)	2346 (92.4)	2346 (92.4)	2369 (93.2)
T. Rear, mm (in)	1433 (56.4)	1606 (63.2)	1599 (63.0)	1796 (70.7)	1789 (70.4)	1789 (70.4)
U. Rear axle to bumper, mm (in)	858 (33.8)	924 (36.4)	924 (36.4)	1042 (41.0)	1036 (40.8)	1036 (40.8)
V. Gauge, mm (in)	1248 (49.2)	1371 (53.9)	1448 (56.9)	1448 (57)	1448 (57)	1529 (60.2)
W. Overall width, mm (in)	1518 (59.8)	1642 (64.6)	1755 (69.1)	1773 (69.8)	1773 (69.8)	1875 (73.4)



# Skid Steer Loader Specifications

ENGINE	L315*	L318	L320	L323	L325	L330
Manufacturer/Model	ISM/N844LT-D-ROW	ISM/N844LT-D-ROW	ISM/N844LT-D-ROW	FPT / F5C E5454 G*A001	FPT / F5C E5454 B*A005	FPT / F5C E5454 C*A003
Type	Diesel 4 times, I.D.I. - Tier III	Diesel 4 times, I.D.I. - Tier III	Diesel 4 times, I.D.I. - Tier III	Diesel 4 times, I.D.I. - Tier III	Diesel 4 times, I.D.I. - Tier III	Diesel 4 times, I.D.I. - Tier III
Cylinders	4	4	4	4	4	4
Bore/stroke, mm (in)	84 x 100 (3.31 x 3.94)	84 x 100 (3.31 x 3.94)	84 x 100 (3.31 x 3.94)	99 x 104 ( 3.9 x 4.1)	99 x 104 ( 3.9 x 4.1)	99 x 104 ( 3.9 x 4.1)
Displacement, cm <sup>3</sup> (in <sup>3</sup> )	2.216 (135.2)	2.216 (135.2)	2.216 (135.2)	3.2 (195)	3.2 (195)	3.2 (195)
Fuel injection	Indirect	Indirect	Indirect	Direct	Direct	Direct
Fuel filter	In-line filter with water separator	In-line filter with water separator	In-line filter with water separator	In-line filter with water separator	In-line filter with water separator	In-line filter with water separator
Air intake	Turbocharged w/ EGR internal	Turbocharged w/ internal EGR	Turbocharged w/ internal EGR	Turbocharged w/ external EGR	Turbocharged w/ external EGR	Turbocharged w/ external EGR
Cooling	Liquid	Liquid	Liquid	Liquid	Liquid	Liquid
<b>Engine speed</b>						
High – no load, rpm	3140 ± 40	3140 ± 40	3140 ± 40	2675 ± 75	2675 ± 75	2675 ± 75
Nominal – full load, rpm	2900	2900	2900	2500	2500	2500
Low, rpm	1200 ± 30	1200 ± 30	1200 ± 30	1075 ± 75	1075 ± 75	1075 ± 75
<b>Power</b>						
Gross hp (kW) – (SAE J1995)	60 (44.7) @ 2.800 rpm	60 (44.7) @ 2900 rpm	60 (44.7) @ 2900 rpm	74 (55) @ 2,500 rpm	82 (61) @ 2500 rpm	90 (67) @ 2500
Net hp (kW) – (SAE J1349)	57 (42.4) @ 2800 rpm	57 (42.4) @ 2900 rpm	57 (42.4) @ 2800 rpm	68 (51) @ 2500 rpm	76 (57) @ 2500 rpm	84 (63) @ 2500
Maximum torque Nm (lb.ft)	171 (126) @ 1.800	171 (126) @ 1.800	171 (126) @ 1.800	203 (275) @ 1400	225 (305) @ 1400	251 (340) @ 1400
FORCE TRAIN	L315*	L318	L320	L323	L325	L330
Mechanically driven pump						
Pump/motor ratio	01:01	01:01	01:01	01:01	01:01	01:01
Displacement, cm <sup>3</sup> (in <sup>3</sup> )	35 (2.14)	35 (2.14)	35 (2.14)	46 (2.81)	46 (2.81)	46 (2.81)
Flow, l/min (gpm)	98 (25.9)	98 (25.9)	98 (25.9)	111 (29.4)	111 (29.4)	111 (29.4)
Loading pressure, psi (bar)	360 (24.5)	360 (24.5)	360 (24.5)	360 (24.5)	360 (24.5)	360 (24.5)
System relief pressure, psi (bar)	5000 (345)	5000 (345)	5000 (345)	5220 (360)	5220 (360)	5220 (360)
Control	Direct mechanic	Direct mechanic	Direct mechanic	Direct mechanic	Direct mechanic	Direct mechanic
<b>Traction engines</b>						
Displacement, cm <sup>3</sup> (in <sup>3</sup> )	325 (19.8)	325 (19.8)	325 (19.8)	470 (28.7)	470 (28.7)	470 (28.7)
High speed displacement (optional), cm <sup>3</sup> (in <sup>3</sup> )	35 (2.14)	35 (2.14)	35 (2.14)	46 (2.81)	46 (2.81)	46 (2.81)
Speed at rated engine rotation	313	313	313	241	241	241
Optional high speed, rpm	N/A	443	443	355	355	355
Torque at maximum flow and relief pressure, Nm (lb-ft)	1783 (1315)	1783 (1315)	1783 (1315)	2694 (1987)	2694 (1987)	2694 (1987)
<b>Displacement speed</b>						
Speed, Km/h (mph)	12.7 (7.9)	12.7 (7.9)	12.7 (7.9)	11.3 (7.0)	11.3 (7.0)	11.3 (7.0)
High speed (optional), Km/h (mph)	18 (11.2)	18 (11.2)	18 (11.2)	16.9 (10.5)	16.9 (10.5)	16.9 (10.5)
Final command	Chain drive, with single reduction	Chain drive, with single reduction	Chain drive, with single reduction	Chain drive, with single reduction	Chain drive, with single reduction	Chain drive, with single reduction
<b>Drive chain</b>						
Size	ASA #80	ASA #80	ASA #80	ASA #100	ASA #100	ASA #100
<b>Axles</b>						
Diameter, mm (in)	50.8 (2)	50.8 (2)	50.8 (2)	62 (2.44)	62 (2.44)	62 (2.44)
Length, mm (in)	346 (13.2)	384 (15.1)	384 (15.1)	396 (15.6)	396 (15.6)	396 (15.6)
<b>Parking break</b>						
Type	To disc, with spring loading and hydraulically released	To disc, with spring loading and hydraulically released	To disc, with spring loading and hydraulically released	Disc, spring loaded and hydraulically released	To disc, with spring loading and hydraulically released	To disc, with spring loading and hydraulically released
Coupling	Press the brake on/off button on the instrument panel, disconnect the abdominal belt, leave the seat or turn off the engine	Press the brake on/off button on the control panel instruments, disconnect abdominal belt, leave the seat or turn off the engine	Press the brake on/off button on the control panel instruments, disconnect abdominal belt, leave the seat or turn off the engine	Press the brake on/off button on the control panel instruments, disconnect abdominal belt, leave the seat or turn off the engine	Press the brake on/off button on the control panel instruments, disconnect abdominal belt, leave the seat or turn off the engine	Press the brake on/off button on the control panel instruments, disconnect abdominal belt, leave the seat or turn off the engine

# Skid Steer Loader Specifications

<b>HYDRAULIC SYSTEM</b>	<b>L315*</b>	<b>L318</b>	<b>L320</b>	<b>L323</b>	<b>L325</b>	<b>L330</b>
Bombs						
Type	Gears	Gears	Gears	Gears	Gears	Gears
Standard displacement, cm <sup>3</sup> (in <sup>3</sup> )	20.4 (1.24)	24.9 (1.52)	24.9 (1.52)	34.1 (2.08)	34.1 (2.08)	34.1 (2.08)
High flow displacement, cm <sup>3</sup> (in <sup>3</sup> )	N/A	N/A	N/A	N/A	N/A	N/A
Pump flow, l/min, gal/min	59 (15.6)	72 (19.1)	72 (19.1)	85 (22.5)	85 (22.5)	85 (22.5)
High flow pump flow, l/min, gal/min	N/A	109	109	131	131	131
Skid Steer Loader control valve						
Type	3 reels/open center/ in series	3 reels/open center/ in series	3 reels/open center/ in series	3 reels/open center/ in series	3 reels/open center/ in series	3 reels/open center/ in series
Relief pressure, psi (bar)	3.046 (210)	3.046 (210)	3.046 (210)	3.046 (210)	3.046 (210)	3.046 (210)
Relief pressure						
Arm lift, psi (bar)	3.263 (225)	3.263 (225)	3.263 (225)	3.263 (225)	3.263 (225)	3.263 (225)
Bucket discharge, psi (bar)	3.770 (260)	3.770 (260)	3.770 (260)	3.770 (260)	3.770 (260)	3.770 (260)
Bucket retraction, psi (bar)	1.160 (80)	1.160 (80)	1.160 (80)	1.160 (80)	1.160 (80)	1.160 (80)
<b>CYLINDERS</b>	<b>L315*</b>	<b>L318</b>	<b>L320</b>	<b>L323</b>	<b>L325</b>	<b>L330</b>
Lift cylinder						
Inner diameter, mm (in)	57.2 (2.25)	57.2 (2.25)	63.5 (2.5)	63.5 (2.5)	63.5 (2.5)	69.9 (2.75)
Shank diameter, mm (in)	34.9 (1.38)	34.9 (1.38)	44.5 (1.75)	44.5 (1.75)	44.5 (1.75)	44.5 (1.75)
Stroke, mm (in)	645 (25.4)	681 (26.81)	681 (26.81)	851.9 (33.5)	851.9 (33.5)	847.9 (33.4)
Closed length, mm (in)	989 (38.94)	982 (38.66)	982 (38.66)	1192 (46.9)	1192 (46.9)	1196 (47.1)
Bucket cylinders						
Inner diameter, mm (in)	57.2 (2.25)	63.5 (2.5)	69.9 (2.75)	76.2 (3)	76.2 (3)	76.2 (3)
Shank diameter, mm (in)	31.7 (1.25)	34.9 (1.38)	34.9 (1.38)	38.1 (1.5)	38.1 (1.5)	38.1 (1.5)
Stroke, mm (in <sup>3</sup> )	370.1 (14.57)	410 (16.14)	410 (16.14)	410 (16.4)	410 (16.4)	410 (16.4)
Closed length, mm (in)	594 (23.38)	610 (24.02)	610 (24.02)	610 (24)	610 (24)	610 (24)
<b>ELECTRIC SYSTEM</b>	<b>L315*</b>	<b>L318</b>	<b>L320</b>	<b>L323</b>	<b>L325</b>	<b>L330</b>
Alternator (Shielded optional)	120 A	120 A	120 A	120 A	120 A	120 A
Starter engine (kW)	12V, 2,2 kW	12V, 2,2 kW	12V, 2,2 kW	12 V, 3,2 kW	12 V, 3,2 kW	12 V, 3,2 kW
Battery	12 V, 925 CCA	12 V, 925 CCA	12 V, 925 CCA	12 V, 925 CCA	12 V, 925 CCA	12 V, 925 CCA
<b>WEIGHTS</b>	<b>L315*</b>	<b>L318</b>	<b>L320</b>	<b>L323</b>	<b>L325</b>	<b>L330</b>
Operating weight kg (lbs)	2430 (5370)	2832 (6230)	2930 (6470)	3350 (7400)	3580 (7900)	3765 (8300)
Transportation weight, kg (lbs)	2300 (5070)	2695 (5930)	2795 (6170)	3200 (7065)	3430 (7565)	3610 (7965)
<b>SERVICE CAPABILITIES</b>	<b>L315*</b>	<b>L318</b>	<b>L320</b>	<b>L323</b>	<b>L325</b>	<b>L330</b>
Fuel tank, l(gal)	60,5 (16)	75.7 (20)	75.7 (20)	96.5 (25.5)	96.5 (25.5)	96.5 (25.5)
Engine oil (with filter), l(gal)	7.1 (1.9)	7.1 (1.9)	7.1 (1.9)	9 (2.4)	9 (2.4)	9 (2.4)
Hydraulic System						
Tank, l(gal)	29.2 (8)	38.1 (10)	38.1 (10)	45.4 (12)	45.4 (12)	45.4 (12)
Chain reservoirs (each side), l(gal)	6.25 (1.65)	7.4 (1.95)	7.4 (1.95)	22.2 (5.9)	22.2 (5.9)	22.2 (5.9)
<b>PERFORMANCE CAPABILITIES</b>	<b>L315*</b>	<b>L318</b>	<b>L320</b>	<b>L323</b>	<b>L325</b>	<b>L330</b>
Operation Load						
50% of tipping load kg (lbs)	680 (1500)	818 (1800)	905 (2000)	1020 (2250)	1135 (2500)	1360 (3000)
Tipping load kg (lbs)	1361 (3000)	1633 (3600)	1814 (4000)	2045 (4500)	2268 (5000)	2722 (6000)
Disintegration force						
Lift cylinder, kN (lbf)	14.1 (3160)	11.7 (2620)	15.3 (3450)	22.6 (5080)	22.6 (5080)	28.2 (6350)
Bucket cylinder, kN (lbf)	18.6 (4180)	24.7 (5550)	32.5 (7300)	38.3 (8620)	38.3 (8620)	38.3 (8620)
Cycle times						
Lift, sec.	3.5	2.8	3.5	3.9	3.9	4.6
Lower, sec.	2.2	2.3	2.3	2.5	2.5	2.7
Dump, sec.	2	2.1	2.6	2.7	2.7	2.7
Rewind, sec.	1.4	1.5	2.0	2.0	2.0	2.0

**For all dimension and performance data, unless the machines have different specifications from those listed below:**

L315 – Equipped with 80 kg operator, 72” extended low profile buckets and 10 x 16,5 tires  
 L318 – Equipped with 80 kg operator, 72” extended low profile buckets and 10 x 16,5 tires  
 L320 - Equipped with 80 kg operator, 72” extended low profile buckets and 12 x 16,5 tires

L323 - Equipped with 80 kg operator, 78” extended low profile buckets and 12 x 16,5 tires  
 L325 - Equipped with 80 kg operator, 78” extended low profile buckets and 12 x 16,5 tires  
 L330 - Equipped with 80 kg operator, 78” extended low profile buckets and 12 x 16,5 tires

# Tire options for the 300 Series Skid Steer Loaders

FACTORY TIRES OPTIONS						
DESCRIPTION	L315	L318	L320	L323	L325	L330
10X16.5 HVY DUTY 590TW	D					
10X16.5 HVY DUTY 640TW		D	D			
12X16.5 HVY DUTY 700TW		X	X	D	D	D
14X17.5 PREMIUM 760TW				X	X	X
TIRE OPTIONS RELEASED AS SPARE PARTS						
10X16.5 HVY DUTY 640TW		D	D			
10X16.5 PREMIUM 640TW		X	X			
10X16.5 SVR DUTY 640TW		X	X			
10X16.5 NON-TIRE 640TW	X	X	X			
10X16.5 TWEEL 640TW	X	X	X			
12X16.5 HVY DUTY 700TW		X	X	D	D	D
12X16.5 PREMIUM 700TW		X	X	X	X	X
12X16.5 PREM-LIN 700TW		X	X	X	X	X
12X16.5 SVR DUTY 700TW			X	X	X	X
12X16.5 TWEEL 700TW				X	X	X

HD



Premium and Premium (w/ Aligner)



Severe service



Non tire



# Bucket Options for the 300 Series Skid Steer Loaders

FACTORY BUCKET OPTIONS							
BUCKET	DESCRIPTION	L315	L318	L320	L323	L325	L330
<b>Dirt &amp; foundry bucket</b>							
BUCKET 72IN DF	72" Dirt & Foundry Bucket (1829 mm), 16.7 cu. ft. Heaped Capacity	X	X	X	X	X	X
<b>Low profile Extended Bucket</b>							
BUCKET 60IN LPE	60" Low Profile Extended (1524 mm), 14.3 cu. ft. Heaped Capacity	X					
BUCKET 66IN LPE	66" Low Profile Extended (1676 mm), 15.5 cu. ft. Heaped Capacity	X	X	X			
BUCKET 72IN LPE	72" Low Profile Extended (1829 mm), 17.1 cu. ft. Heaped Capacity	X	X	X	X	X	X
BUCKET 78IN LPE	78" Low Profile Extended (1981 mm), 18.6 cu. ft. Heaped Capacity		X	X	X	X	X
BUCKET 84IN LPE	84" Low Profile Extended (2134 mm), 20.2 cu. ft. Heaped Capacity		X	X	X	X	X
<b>Heavy Duty Dirt Bucket</b>							
BUCKET 72IN HD	72" Heavy Duty Dirt Bucket (1829 mm), 14.6 cu. ft. Heaped Capacity	X	X	X	X	X	X

\*Other buckets will be available as spare parts



HD Bucket for foundry and grounding



Foundry and grounding bucket



Low profile extended bucket



# FLEETSYSTEMS

## Smart solutions with leading cutting edge technology from New Holland.

New Holland presents the Fleetsystem, a smart system that precisely controls all the movements of the machine, from its behavior to its exact location. The Fleetsystem encompasses telemetry, geopositioning and cut/fill in the field to be performed, it also controls maintenance needs and even takes care of the machine physical security. All this in a simple and pleasant way.

This system is the union of the machine, the project of the work, the fleet management, the total control of expenses, the operational performance, with cutting edge technology, operated by FleetForce and FleetGrade.



# FLEETFORCE™

## Maximize the productivity of your fleet, with effective planning and increase your profitability.

FleetForce New Holland is the telemetry system that collects information about machine performance and location, offering it in an easy-to-use format. With the support of your dealer's FleetForce specialist, you'll get more efficiency, lower operating cost, and increased profitability.

The FleetForce hardware and advanced signature available on New Holland products are seamlessly integrated into the machine through the CAN-bus data system, which allows you to:

- Maximize your fleet productivity**  
 FleetForce provides vital information and performance about your machine. With it, the machines that are not being used or those that are being used to a large extent are identified, the performance or the trend of the machines in fuel consumption during the days are compared and the notifications of the machine are evaluated to optimize the use of their teams. Additionally, you can setup the system to receive scheduled maintenance warning signals in your email.
- Plan effectively**  
 The FleetForce allows you to monitor your fleet, identifying trends in machine performance, operator efficiency, and even the need for training.
- Higher profitability**  
 Your dealership can help in increasing the fleet productivity by analyzing information about the machine, such as data regarding downtime, or need for maintenance, thus maximizing service efficiency.

CHARACTERISTICS OF THE PLAN	BASIC
<b>FLEET MANAGEMENT</b>	
Locate and perform the "ping" (test) of the machines for project management.	✓
Machine hours report.	✓
<b>PLANNED MAINTENANCE</b>	
Plan and prepare maintenance intervals.	✓
<b>SAFETY</b>	
Electronic geographic fence (GeoFence): notifications about unscheduled movements in real time.	✓
Curfew.	✓
<b>ANALYSIS AND USE REPORT</b>	
Reports on down time, engine running, travel time and machine usage.	✓
<b>PERFORMANCE ANALYSIS</b>	
Upload engine data to compare machines and operations to identify operating trends.	-
<b>INFORMATION AND REPORTS ON FUEL</b>	
Consumption data to monitor the use of one machine or the entire fleet.	-
<b>MECHANICAL OPERATING PARAMETERS</b>	
Monitor the machine operating characteristics: temperature, pressure, parameter out-of-range alerts and can-bus parameters for troubleshooting and diagnosis.	-

## **SUBSCRIPTION**

There are three subscription options available, depending on the level of detail in the information:

- The Basic subscription uses the essential inputs of the ignition switch contact, motion detection and GPS tracking to secure a range of information and reports.
- The Satellite connection subscription can be added to the Basic subscription.
- The data update of your equipment with the connection via Satellite can be done every full 4 hours and complete reports can be done every 24 hours.

The Basic options offer a subscription of up to five years, and the subscription of connection via Satellite is of one or two years; you can purchase extensions for everyone at your dealership through the Pieces Department.

- **Control module**

An on-board device collects information about your machine's location, productivity, fuel consumption, scheduled maintenance and operating information and sends it to your FleetForce portal on the Internet.

More information on your dealership.

**supportfleetforce@newholland.com**

**www.newholland.com**



NEW HOLLAND

L330

SUPERBOOM

# AFTER-SALES OF THE AUTHORIZED NEW HOLLAND NETWORK. HIGH PERFORMANCE AND PRODUCTIVITY GUARANTEE.

The Authorized **New Holland** Network offers specialized services, from professionals rigorously trained by the factory and genuine parts with certified quality and origin, as well as full support in the purchase of your equipment and easy financing.

The **New Holland** after-sales service is at your entire disposal to guide and present the best options in hiring authorized services and in the acquisition of parts. With it, high performance and the best performance of the machine is ensured, with all the safety and best cost-benefit.

To access the productivity and high technology that only New Holland offers, count on the **New Holland** Authorized Network's After-sales.



AT YOUR DEALER:

The dimensions, weights and capacities shown in this brochure, as well as any conversion used, are always approximate and subject to normal variations within manufacturing tolerances. New Holland's policy is to continually improve its products and the company reserves the right to modify specifications and materials or make improvements at any time, without prior notice or obligation of any kind. Illustrations do not necessarily show the product in standard conditions.

IONHCE1015 09/2020

COMUNICAÇÕES AMÉRICA LATINA ©

Commercial Bureau:  
Contagem – Minas Gerais – Brazil  
Av. General David Sarnoff, 2.237  
Inconfidentes – ZIPCODE 32210-900  
Phone: 5531 2104-3111

**CNH**  
INDUSTRIAL | CAPITAL



[www.newholland.com](http://www.newholland.com)

A Brand of CNH Industrial

